

# Guidelines for Selecting Air Conditioning for Your Boat

***Cruisair***<sup>®</sup>

by Dometic GROUP



## Understanding Air Conditioning

The basic principle of any air conditioner is the transfer of heat from one element to another. In a direct expansion (DX) seawater-cooled air conditioner, heat is transferred from the cabin air to the refrigerant gas to the seawater. In heating mode, the refrigerant flow is reversed and heat is transferred from the seawater to the refrigerant gas to the cabin air.

In addition to lowering the air temperature, moisture is also removed. Reduced humidity feels more comfortable and helps keep the boat dry, reducing mold growth and other moisture-related problems.

## The Three Types of Marine Air Conditioning Systems

### Self-Contained DX Systems (see Figure 1)

- All major components mounted on a single chassis installed in the living area; usually under a bunk or settee, or in a locker.
- A single unit can cool one cabin or it can be ducted to two or more cabins to save space and cost.
- Best choice for boats up to 40 ft. (12 m) due to lower cost of units and installation.

### Split-Gas DX Systems (see Figure 2)

- Major components are split between two units that are installed in different locations and connected by insulated, copper refrigerant tubing.
  - Condensing unit (compressor, seawater condenser, and electrical components) mounts in engine room or other mechanical space.
  - Evaporator unit installs in living area. Two air handlers can connect to one condensing unit to cool multiple cabins or a single large area.
- Air handlers require less space in living area and system is quieter because compressor is in engine room.
- For boats up to 80 ft. (24 m). Maximum length of refrigerant tubing between the condenser and air handlers is 50 ft. (15 m) and system must be charged with refrigerant by a certified technician.

### Chilled Water Systems (see Figure 3)

- Chiller unit in engine room cools (or heats) fresh water that is pumped through an insulated piping loop to air handlers located in the living spaces that cool (or heat) the air.
- Chillers offer flexible load management and a reduced peak electrical load.
- For boats over 80 ft. (24 m). No limitation on the number of air handlers in a system, or on the distance from the chiller to the air handlers.

**Figure 1 — Self-Contained DX System**

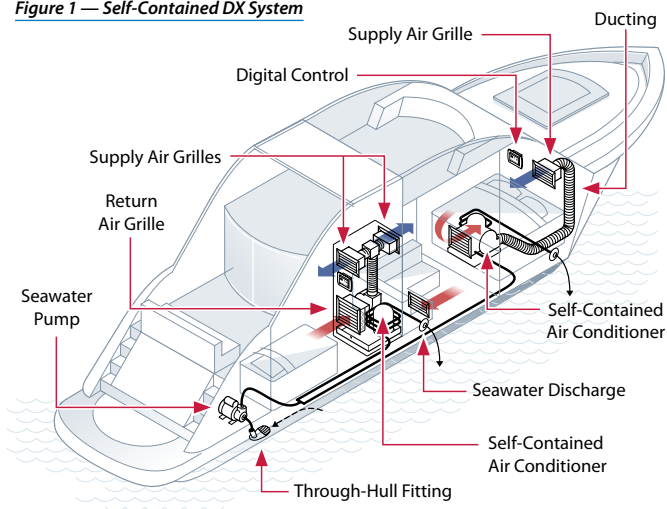

**Figure 2 — Split DX System**

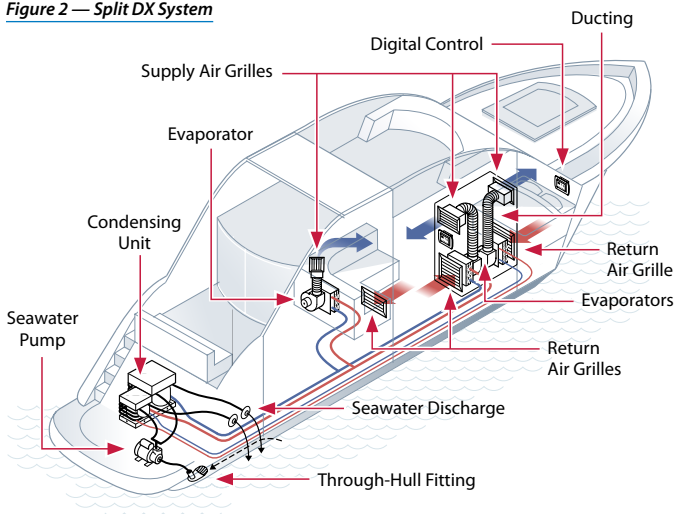

**Figure 3 — Chilled Water System**

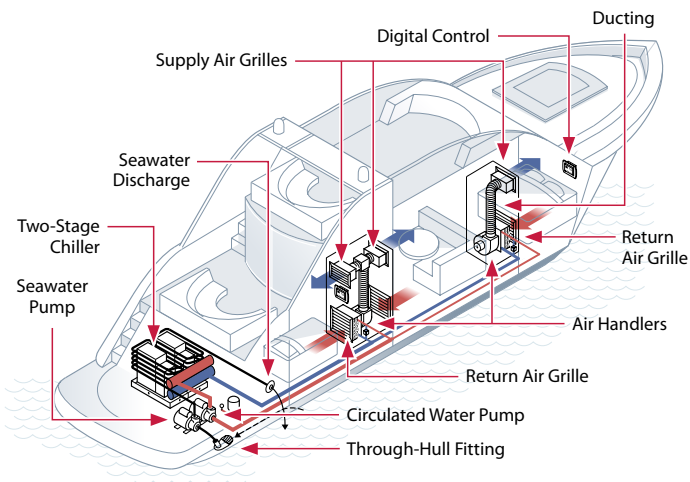

## Factors That Determine the Type of System You Need

1. Size and layout of boat for calculating required system capacity.
2. Access for routing tubes/wires/hoses.
3. Location of furnishings.
4. Storage space to sacrifice.
5. Cost.

## How to Size Your System

**Step 1.** Find the required capacity by dividing the vessel into three main load areas:

1. Below Deck. Cabins where the hull slopes inward toward the keel with minimal port lights and hatches.
2. Mid Deck. Areas on main deck with small or shaded windows.
3. Above Deck. Areas with large glass surfaces and direct sunlight.

Multiply the length and width of each cabin to be treated to determine the area in square feet or square meters. It is assumed the boat has average headroom of about 6.5 ft. (2 m) with an average amount of furniture. If one end of the cabin is narrower than the other, take your measurement in the middle.

Using **Table 1**, multiply the area of each cabin by the appropriate load factor to find the required air conditioner capacity. For example, if your boat is in a temperate climate and you are measuring in square feet, you would multiply your total below-deck area by 60, your mid-deck area by 90, and your above-deck area by 120.

Table 1

Climate	Below-Deck Load Factors	Mid-Deck Load Factors	Above-Deck Load Factors
Temperate <sup>(1)</sup>	60 (sq. ft.) 645 (sq. m)	90 (sq. ft.) 968 (sq. m)	120 (sq. ft.) 1291 (sq. m)
Tropical <sup>(2)</sup>	80 (sq. ft.) 968 (sq. m)	120 (sq. ft.) 1291 (sq. m)	150 (sq. ft.) 1614 (sq. m)

<sup>(1)</sup> Temperate: 95°F (35°C) air, 85°F (35°C) water, moderate humidity.

<sup>(2)</sup> Tropical: 105°F (41°C) air, 95°F (35°C) water, high humidity.

**Step 2.** Taking into account the boat's size and layout, determine the *number* of self-contained systems or air handlers needed.

Find out which cabins or areas will benefit best from a dedicated thermostat control, and which cabins can be served by ducting or a secondary air handler (where the only temperature control is an adjustable grille or fan-speed control).

**Step 3.** Taking into account the boat's size and layout, determine the *location* of each self-contained system or air handler.

In addition to leaving enough room for plumbing and ducting, there must also be sufficient space in each installation location for servicing and/or removal of the unit.

A self-contained unit or air handler must have an open return-air path. However, the return-air grille does not need to be directly in front of the unit. In fact, the system will be less noisy if there is an indirect path for the return air to follow. Never install the unit in the bilge or engine room or where vapors from these areas could reach the unit.

A self-contained unit or air handler must be located so the discharge ducting can be routed to a high point in the cabin. Rotate the blower to create the most direct path for routing the discharge duct. Poor airflow may result from a ducting run of over 15 ft. (4.5 m) or a ducting run with many bends. Plan for the shortest possible ducting run while limiting the number of bends.

**Step 4.** Seawater Components. Use one pump of adequate capacity for all air conditioning systems on board. The basic rule is 250 gallons per hour (4 gpm) of water per ton of air conditioning (one ton is 12,000 BTU). If more than one system shares a common pump, you will also need a pump relay and manifold.

The BTU capacity in **Table 2** shows recommended seawater flow rates and minimum inlet (through-hull) sizes.

Table 2

System Capacity	Seawater Flow Rate <sup>(3)</sup> (GPH/LPH)	Through-Hull Inlet Size (in/mm)
5K-12K BTU/hr.	250/945	0.50/13
16K-24K BTU/hr.	500/1,890	0.75/19
30K-48K BTU/hr.	1,000/3,785	1.00/25

<sup>(3)</sup> Allow for a reduction in capacity if using a 60Hz pump at 50Hz.

**Step 5.** Determine the proper duct diameter ( $\emptyset$ ) and grille sizes for your air conditioning system. Use Table 3 to find the correct sizes, which are based on the system's BTU capacity.

Table 3

System Capacity	Duct $\emptyset$ (in/mm)	Return-Air Grille (ft <sup>2</sup> /cm <sup>2</sup> )	Discharge-Air Grille (ft <sup>2</sup> /cm <sup>2</sup> )
5K BTU/hr.	3.94/100	60/387	30/194
7K BTU/hr.	4.92/125	80/516	45/290
10K BTU/hr.	5.91/150	100/645	60/387
12K BTU/hr.	5.91/150	130/839	70/452
16K BTU/hr.	6.90/175	160/1,032	80/516
18K BTU/hr.	6.90/175	200/1,290	100/645

## Other System Components

A complete air conditioning system requires controls, a seawater cooling system, an air-distribution system and electrical connections.

### Controls

There are two types of controls: digital and mechanical (rotary-knob switch).

- **Digital.** These keypad/displays are part of a microprocessor system with many advanced functions, including automatic fan-speed control, fault display, and a dehumidification program. Decorative bezels can be added to match your interior design.
- **Mechanical.** These manual switches with two or three rotary knobs control the mode of operation, thermostat, and variable fan speed. Reverse-cycle models have automatic changeover between heating and cooling.

### Seawater Cooling System

The seawater cooling system brings seawater into and through the system then discharges it overboard. It consists of an inlet through-hull fitting, seacock (water valve), strainer, pump, and overboard discharge fitting, all connected by hose or piping (see Figure 4).

Figure 4

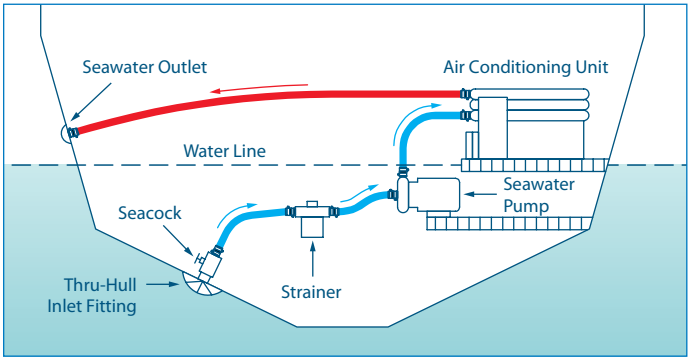

If multiple air conditioning units are served by a single seawater pump, then a pump relay and water manifold are required. A centrifugal seawater pump is recommended for efficient, quiet operation and long life. Centrifugal pumps are not self-priming and must be mounted below the water-line.

It is important that the seawater plumbing be self-draining, meaning that if the boat is lifted, all water in the piping will drain out. An air conditioning system plumbed this way will have no air locks which could disrupt the flow of seawater.

For shallow-draft boats where it is impossible to mount the pump below the water-line, a self-priming pump must be used.

### Air-Distribution System

Cabin air is drawn into the self-contained unit or air handler through a return-air grille. It is then cooled (or warmed) and blown back into the cabin through a ducting system.

The supply-air grille should be positioned high in the cabin and away from the return-air grille to ensure good circulation. Plenums (transition boxes) can be installed in the ducting to split the air flow into multiple ducts to serve one or more cabins.

Figure 5 illustrates an air conditioning unit or air handler in cooling mode installed beneath a bunk. Ducting should be insulated to prevent secondary condensation. An air filter, located on the cooling unit or on the return-air grille, must be cleaned or replaced regularly.

Figure 5

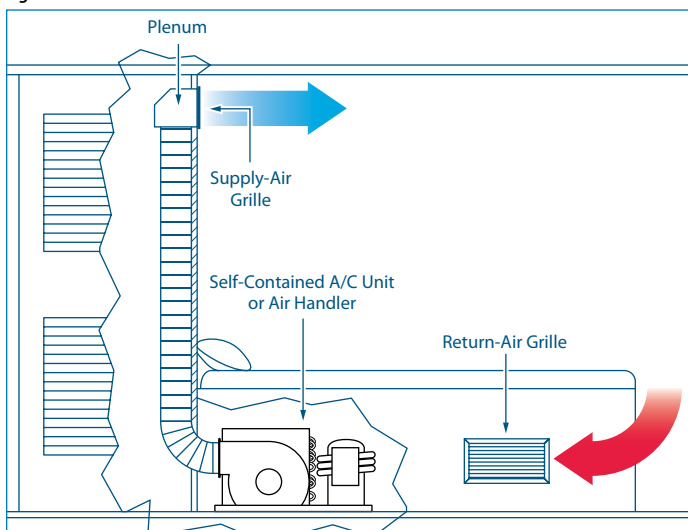

## Electrical Connections

Most Dometic air conditioning systems are available in three power configurations: 115V 60Hz, 230V 60Hz, and 220V-240V 50Hz. Larger systems are available with three-phase compressors. Some 60Hz units can run at 50Hz, but not all.

Please check the specification sheet or contact your Dometic dealer if you have a particular power requirement.

Wire sizing should be done per ABYC requirements.

Selecting the circuit breaker for the system:

- Multiply the running (heat) amps by 2.5 then choose the next higher-size breaker.
- If the seawater pump is wired with the unit (not on a pump relay), then add in the pump amps before multiplying by 2.5.

## Using a Generator

If running on a generator, make sure that it can handle the large starting inrush current of the compressor. Use of a Dometic SmartStart™ is highly recommended to smooth out starter demand and ease strain on the generator.

Take the product specification sheets to your generator supplier and ask for their help.

## Largest Certified Sales & Service Network



To find a sales and service dealer near you, go to:

[www.dometic.com/marinedealers](http://www.dometic.com/marinedealers)

### **DOMETIC MARINE DIVISION**

2000 N. Andrews Ave. Ext. | Pompano Beach, FL 33069 USA

954-973-2477 | Fax 954-979-4414

[www.DometicUSA.com](http://www.DometicUSA.com) | [MarineSales@DometicUSA.com](mailto:MarineSales@DometicUSA.com)

### **24/7 Tech Support for United States & Canada:**

8:00 AM to 5:00 PM Eastern Time: 800-542-2477

After hours and weekends: 888-440-4494

### **International Sales & Service:**

Europe & the Middle East: Call +44(0)870-330-6101

For all other areas visit our website to find your nearest distributor.



Environmentally  
Responsible

***Cruisair***<sup>®</sup>

by Dometic GROUP